

N24 200

SISTEMA DE BATENTE COM RPT

THERMALLY BROKEN CASEMENT SYSTEM

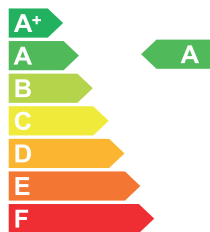

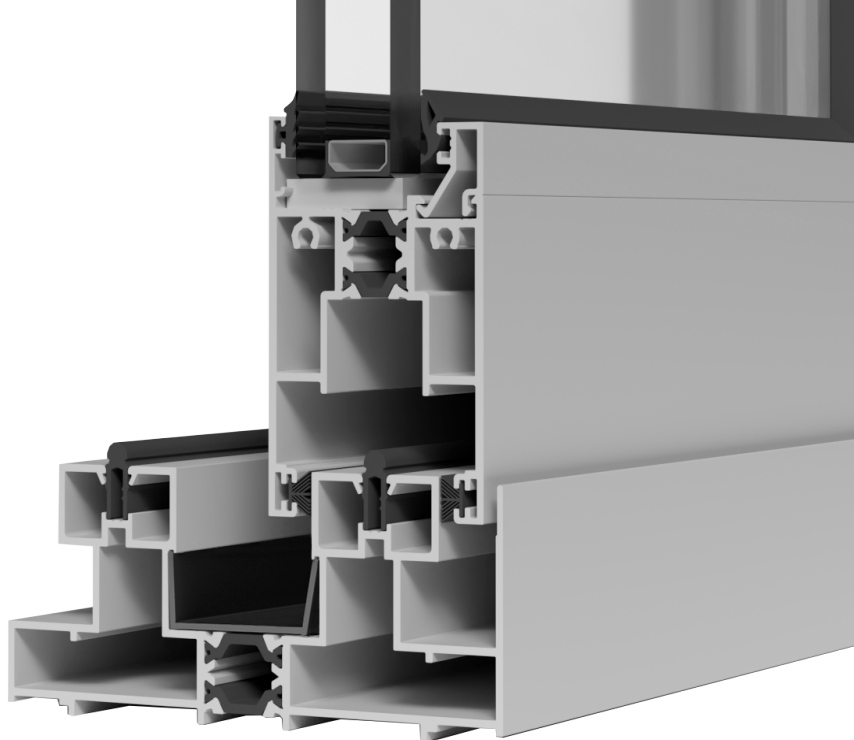

Sistema de correr perimetral com rutura de ponte térmica, linhas retas, aros fixos de 118 mm de profundidade, com opção em tri-rail e quadri-rail, e aros móveis de 81,7 mm de vista. Sistema termicamente melhorado pela inclusão de poliamidas, indo ao encontro das necessidades atuais de qualidade com performances elevadas e de fácil manuseamento.

Com múltiplas soluções construtivas, possibilita a execução de caixilhos de grandes dimensões e vãos bicolores. Permite a execução de vãos de correr tradicionais e folhas de correr eleváveis, mediante um acessório próprio que facilita a manobra e deslizamento da folha.

Com o perfil N24 263, este sistema permite a fabricação de folhas com bite, aumentando a facilidade de fabricação dos caixilhos. O perfil N24 263 permite, também, a fabricação de folhas de correr tradicionais e folhas de correr eleváveis no mesmo caixilho.

Perimetral sliding system with thermal break, featuring clean lines, fixed frames with a depth of 118 mm (available in tri-rail and quadri-rail options), and sliding sashes with a visible section of 81.7 mm.

This system is thermally enhanced through the inclusion of polyamides, meeting current quality standards with high performance and easy operation.

With multiple construction solutions, it allows for the fabrication of large-scale frames and dual-color openings. It supports both traditional sliding windows/doors and lift-and-slide sashes, thanks to a dedicated accessory that improves sash movement and handling.

Using the N24 263 profile, the system enables the production of glazed sashes, simplifying the manufacturing process. The N24 263 profile also allows for the combination of traditional sliding and lift-and-slide sashes within the same frame.

EFICIÊNCIA TÉRMICA E ACÚSTICA

THERMAL AND ACOUSTIC EFFICIENCY

PERMITE FOLHAS DE CORRER ELEVÁVEIS

ALLOWS LIFT-AND-SLIDE SASHES

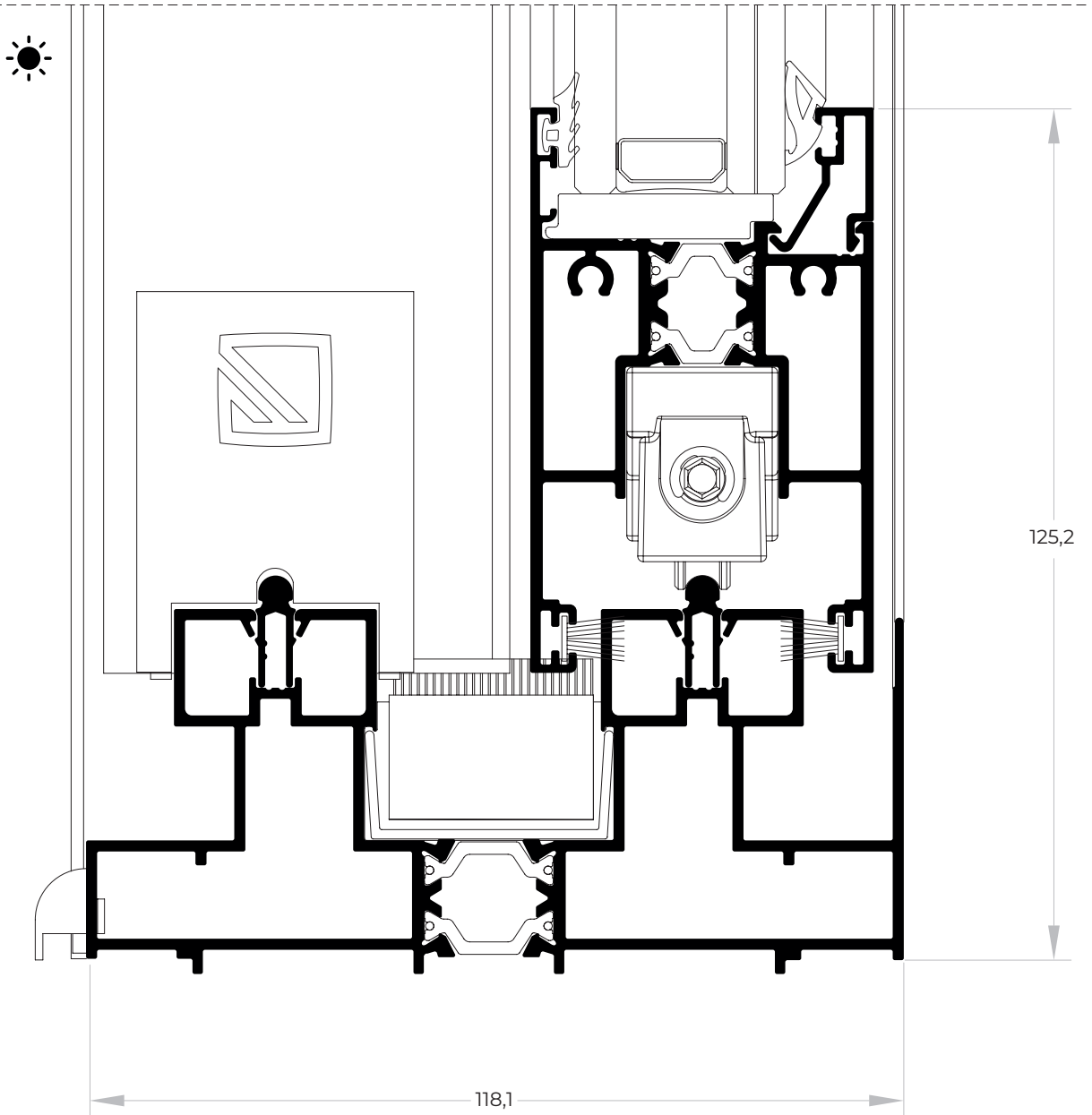

[escala scale 1:1]

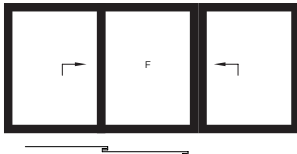
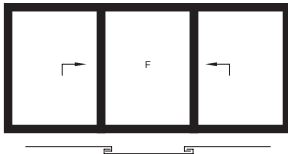
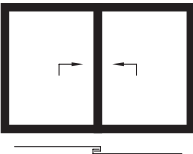
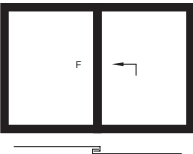
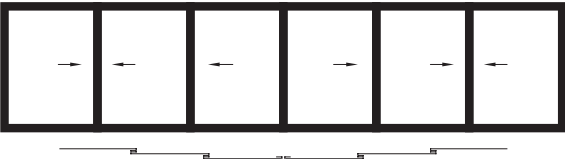
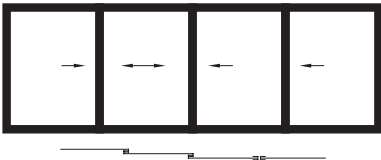
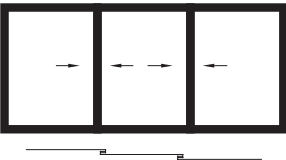
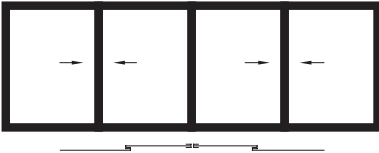
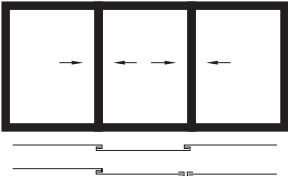
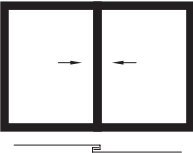



MONTAGENS E TIPOLOGIAS ASSEMBLIES AND TYPOLOGIES

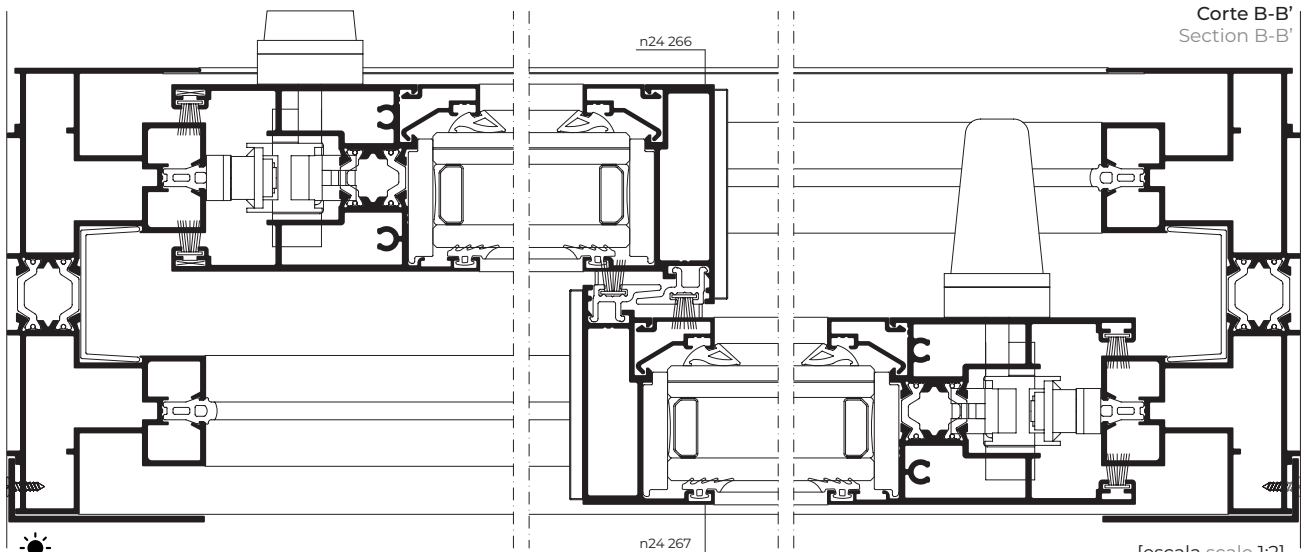
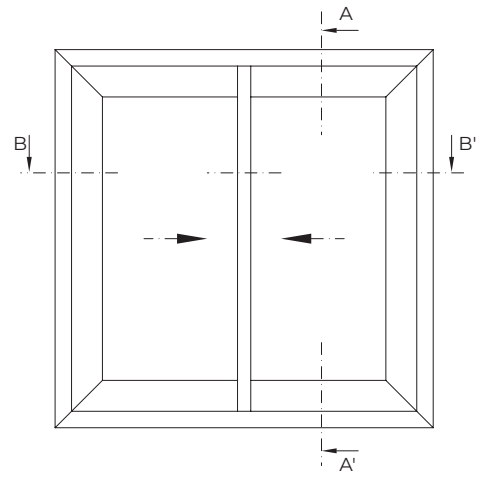
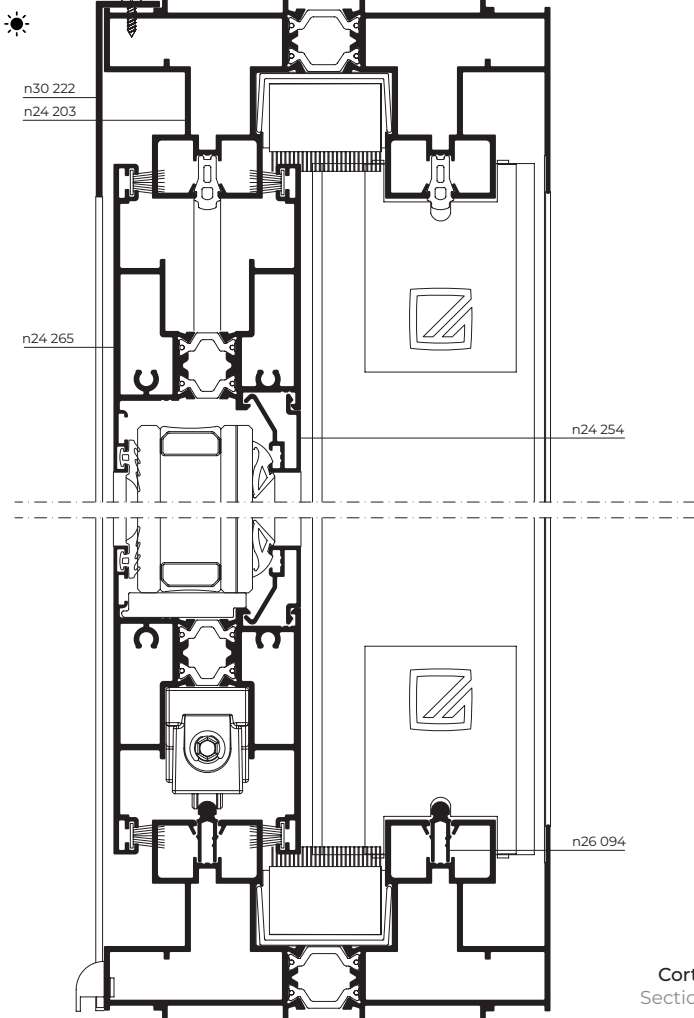

[escala scale 1:2]

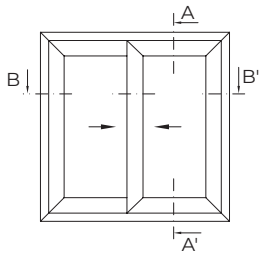
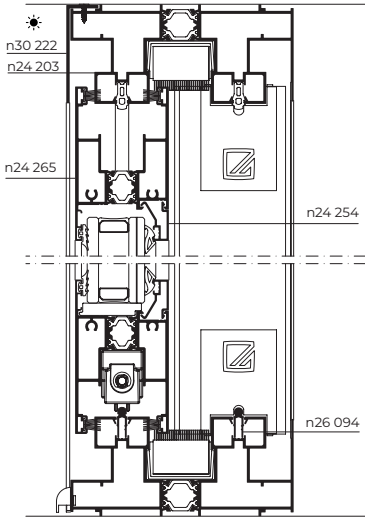

Corte A-A'
Section A-A'

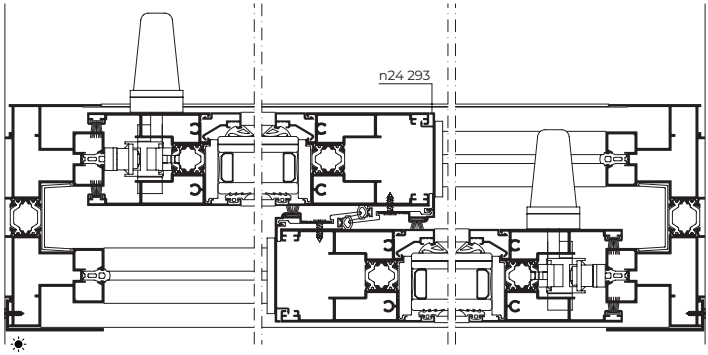

Corte B-B'
Section B-B'



PERFIS PROFILES

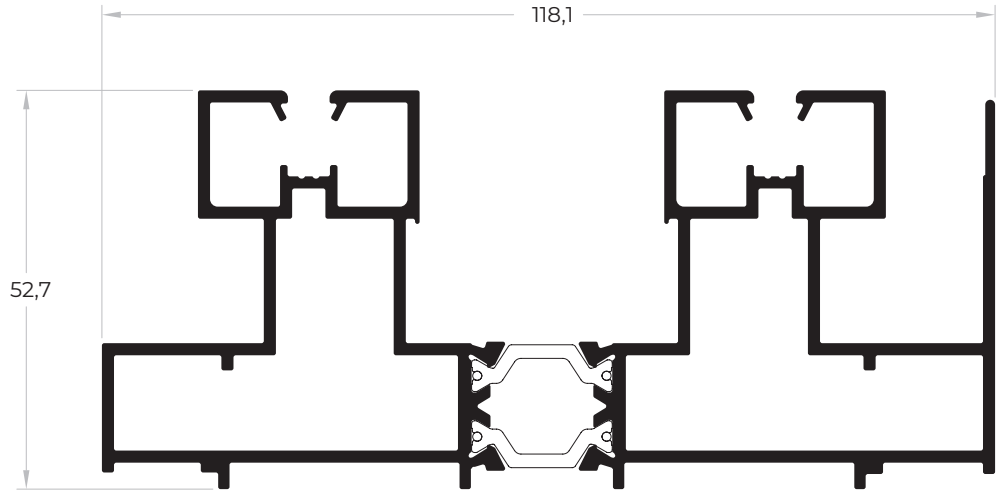

ref: **n24 203**

[escala scale 1:1]

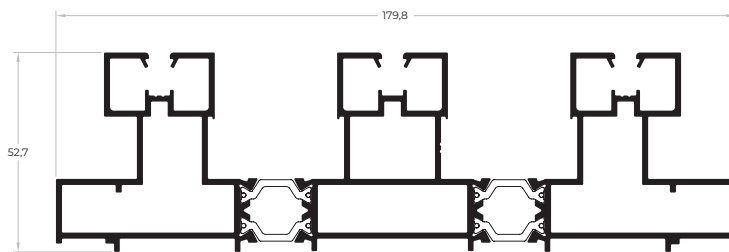

ref: **n24 204**

[escala scale 1:2]

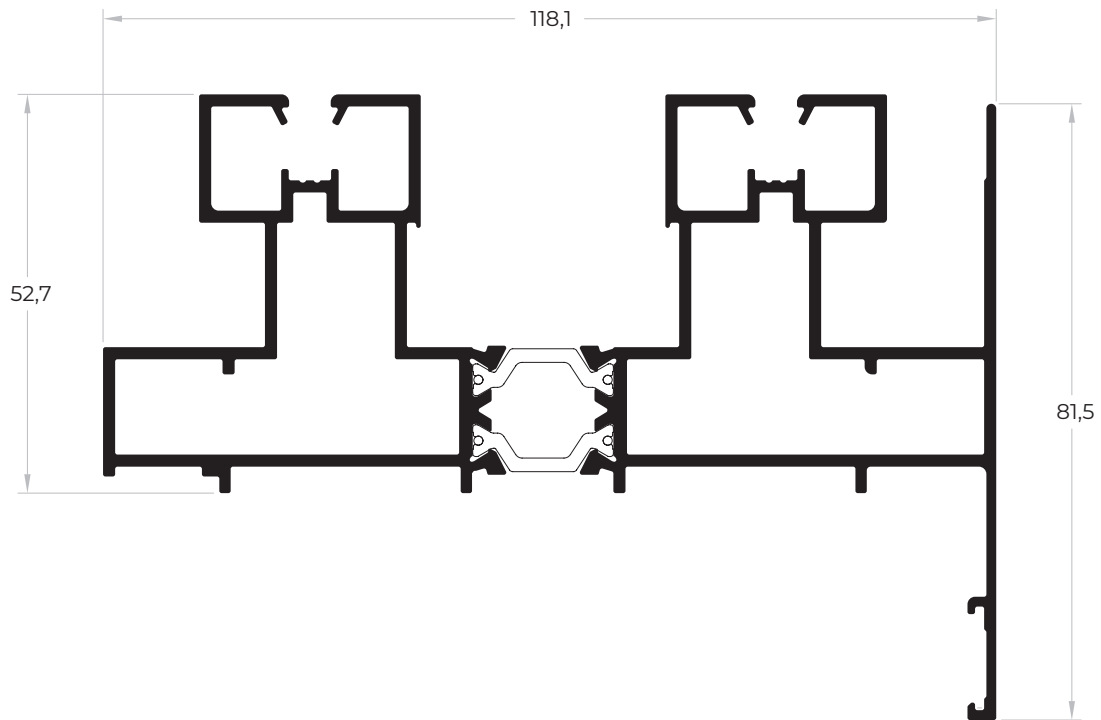

[escala scale 1:1]

ref: **n24 208**

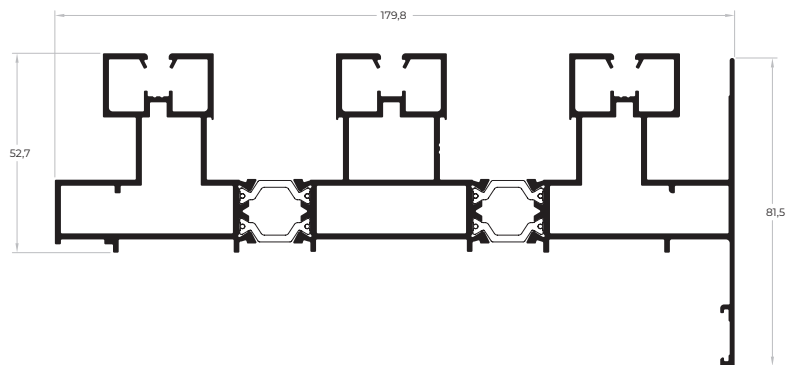

[escala scale 1:2]

ref: **n24 209**



PERFIS PROFILES

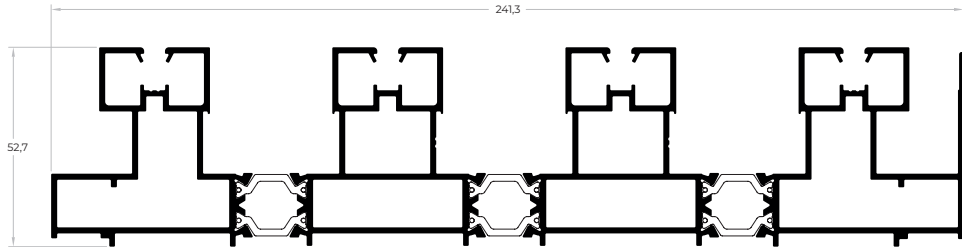

ref: **n24 205**

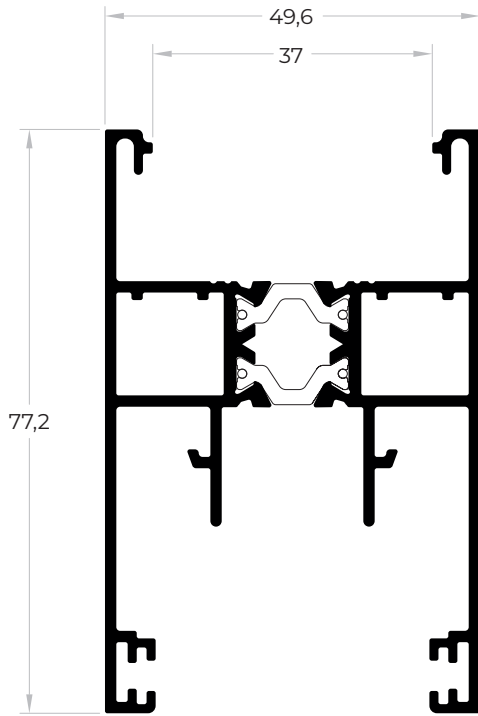

ref: **n24 261**

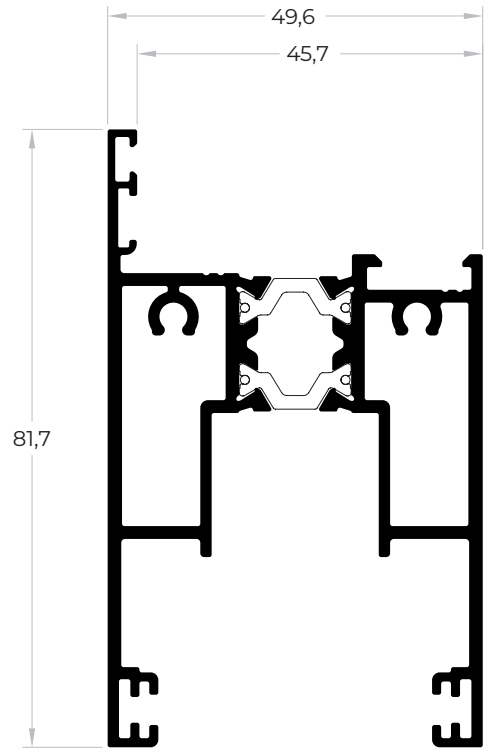

ref: **n24 265**



PERFIS PROFILES

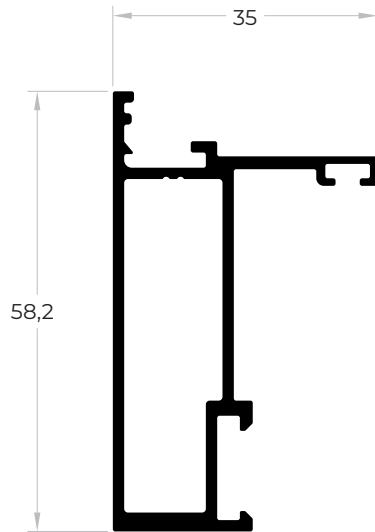

ref: **n24 266**

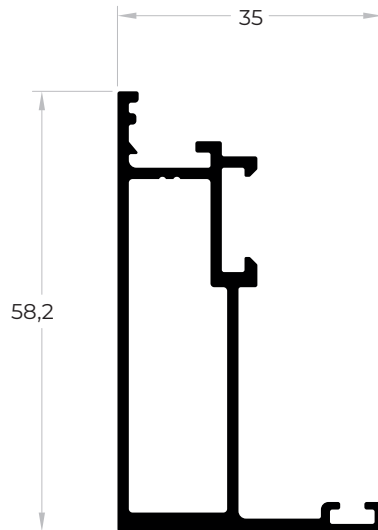

ref: **n24 267**

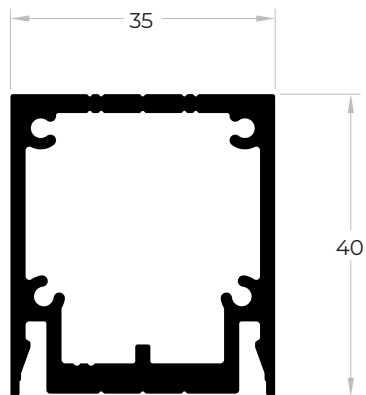

ref: **n31 961**

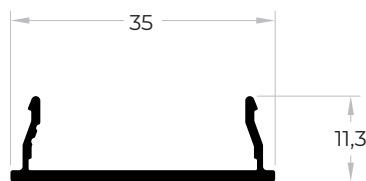

ref: **n31 963**



PERFIS PROFILES

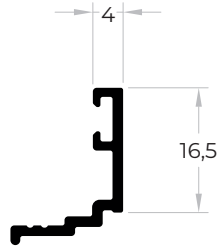

ref: [n24 253](#)

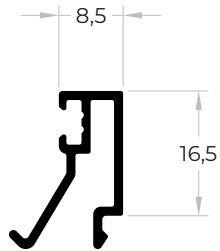

ref: [n24 254](#)

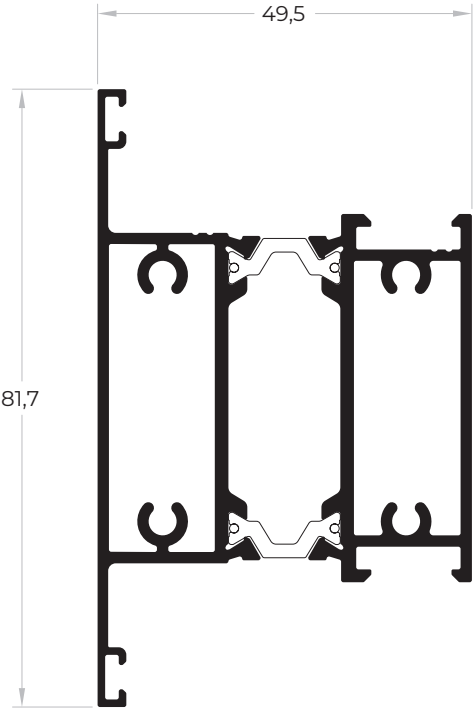

ref: [n24 271](#)



PERFIS PROFILES

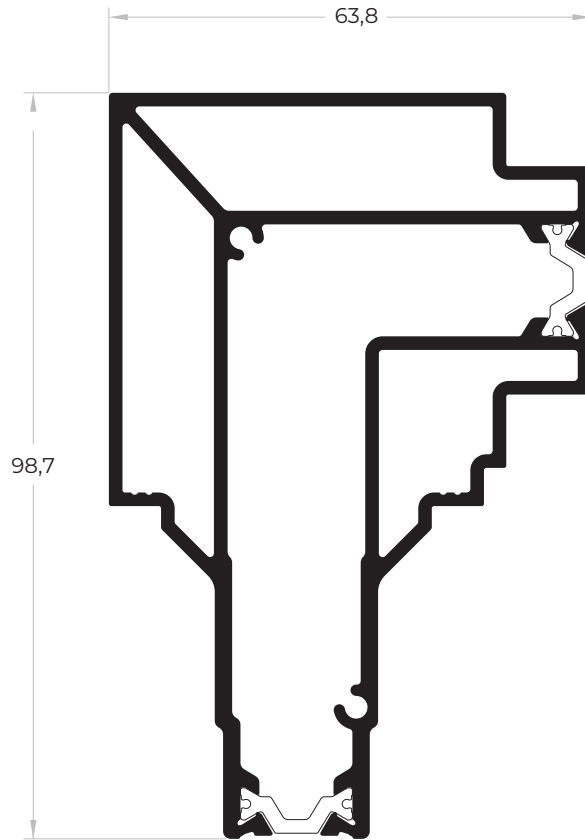

ref: **n24 290**

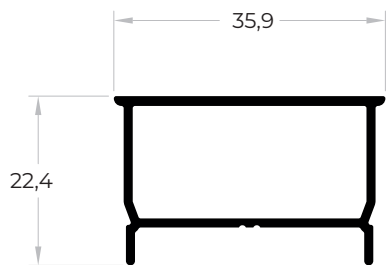

ref: **n24 292**

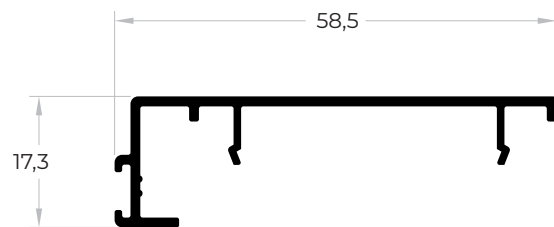

ref: **n24 294**

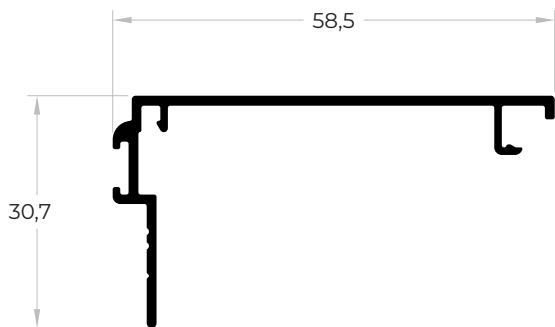

ref: **n24 293**

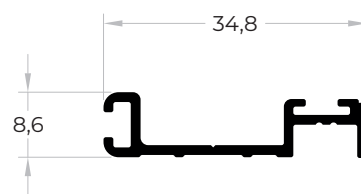

ref: **n24 295**



PERFIS PROFILES

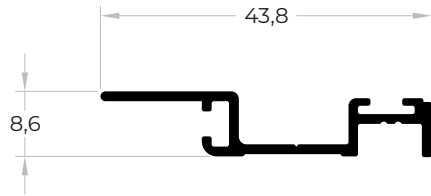

ref: **n24 297**

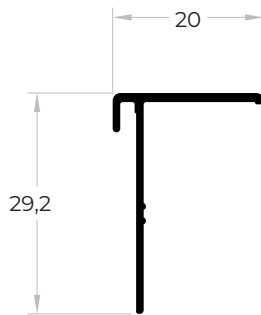

ref: **n21 093**

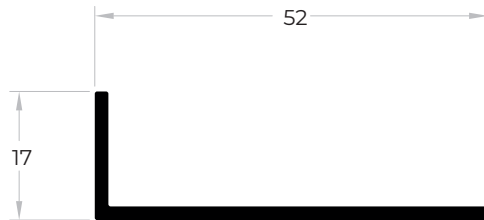

ref: **n30 222**

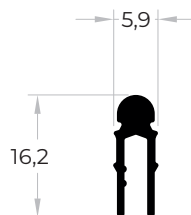

[escala scale 1:1]

ref: **n26 094**

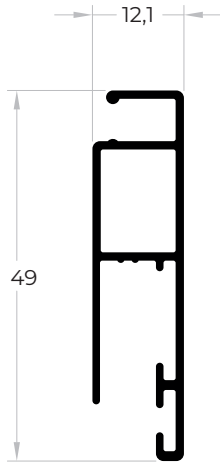

ref: **n31 524**

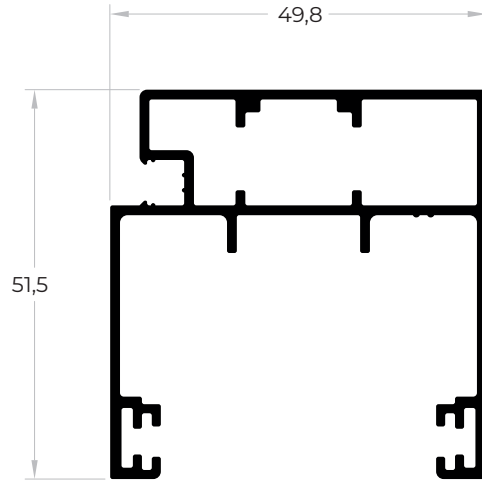

ref: **n31 526**

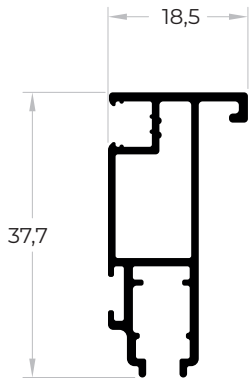

ref: **n31 527**

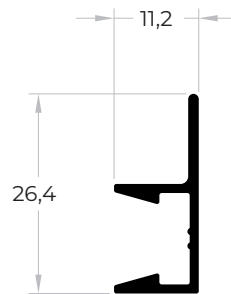

ref: **n31 528**



Conheça esta obra aqui!
Find out more about this work here!



A Navarra - Extrusão de Alumínio, S.A. reserva-se no direito de proceder sem aviso prévio a alterações em todo ou parte do conteúdo apresentado, invalidando todas as versões anteriores.
Navarra - Extrusão de Alumínio, S.A. reserves the right to make unannounced changes to all or part of the content presented, invalidating all previous versions.

EDIFÍCIO SEDE | HEAD OFFICE
SHOWROOM BRAGA | BRAGA SHOWROOM
Navarra - Extrusão de Alumínio, S.A.
Avenida Doutor Domingos Soares, nº 18
4710-670 Braga

COORDENADAS GPS | GPS COORDINATES
41° 36´ 10.582" N
8° 22´ 52.554" W

ENDEREÇO POSTAL | POSTCODE
Navarra - Extrusão de Alumínio, S.A.
Apartado 2476
4701-971 BRAGA

t. + 351 253 603 520
f. + 351 253 677 005
geral@navarraaluminio.com
comercial@navarraaluminio.com
export@navarraaluminium.com

SHOWROOM LISBOA | LISBON SHOWROOM
Parque das Nações
Alameda dos Oceanos
Edifício Mar do Oriente, n.º63 fração 0.1
1900-137 Lisboa

t. + 351 218 965 032
showroomlisboa@navarraaluminio.com

COORDENADAS GPS | GPS LOCATION
38° 46´ 17.4" N
9° 05´ 44.4" W

Edição 2 | 16/03/26
Edition 2 | 16/03/26